

Cadillac[®] Magnetic Flow Meter

Central Station Steam Co.[®]

GENERAL INFORMATION

EMAG Series

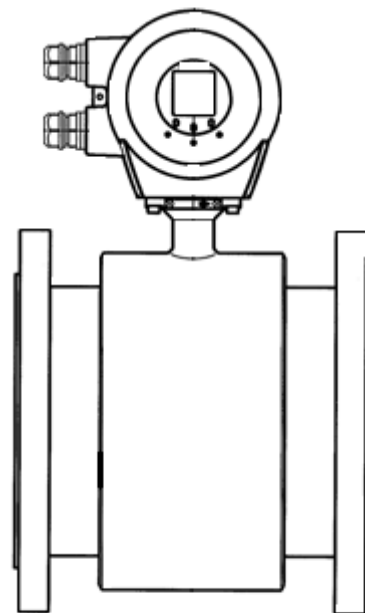
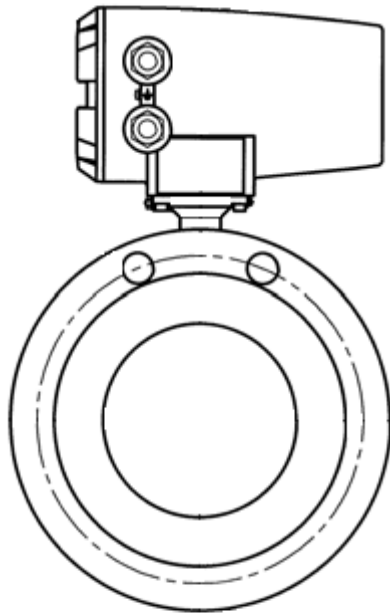

Central Station Steam Co.[®]

CADILLAC[®] METERS

15615 SW 74th Ave., Ste #150

Tigard, OR 97224

www.cadillacmeter.com

Phone: 888-556-3913

Fax: 503-624-6131

THE LIQUID METER OF CHOICE

The economical Cadillac® EMAG magnetic flow meter is a rate and totalizing device, which is capable of measuring liquids of all types and consistency while providing an obstruction free flow path. The Cadillac EMAG is Ideally suited for hot and chilled water. In any heating/cooling system the Cadillac® magnetic flow meter is the number one technology choice due to Cadillac®'s accuracy, linearity, reliability and rangeability.

Like many other flow meters, the Cadillac® magnetic flow meter is a velocity measuring device which computes flow by multiplying the effective cross sectional area of the flow meter with the detected fluid velocity. The meter has no moving parts and consists of a meter body with encapsulated coils, electrodes and an amplifier assembly. It detects velocity by measuring an induced voltage that is developed by moving the conductive fluid through a magnetic field. For a more detailed explanation, please review the "Principle of Operation" below.

THE NEW INDUSTRY STANDARD

Historically, liquid flows have been measured by mechanical flow meters. However, as with any mechanical system, the meters are subject to wear and tear, and require regular maintenance and calibration. Even though magnetic flow meters have been on the market for years, their high cost of manufacture have limited their use. Current manufacturing technology has made the Cadillac® magnetic flow meter a cost effective solution, especially in applications requiring analog (rate) or pulse (totalized) outputs.

APPLICATIONS

- Data Source for energy management system, DCS, district-wide systems.
- Energy-Customer Billing from accurately totalized flow measurements.
- Basis for internal cost distribution using campus-wide systems.
- Process monitoring from central control rooms.
- Cooling/heating load flows for Hydronic systems.
- Process flows of all liquid types (acids, caustics, abrasives, high suspended solids)

FEATURES

- **ACCURACY: +/-0.5% of the reading for liquids.**
High accuracy allows significant improvement in both measurement and customer billing.
- **RANGEABILITY: Typically 100 to 1 turndown or better.**
With seasonal heating/cooling load variation, the need for a large turndown is essential. Cadillac® magnetic flow meters will accurately measure all load requirements with proper sizing.
- **LONGEVITY: Mean time between failure (MTBF) of 75 years.**
With no moving parts and through simple robust design the meter has unmeasured life expectancy.
- **MODERN ELECTRONICS: meeting the challenges of the next millennium**
Meters are equipped with electronics capable of registering locally, remotely or interfacing with an energy management system. Built to withstand the toughest conditions.

PRINCIPLE OF OPERATION

Faraday's law states that, when you move a conductor perpendicular through a magnetic field, a voltage will be induced proportional to the velocity of the conductor. A magnetic field is created by a set of coils which are encapsulated and rigidly retained in the meter flow tube and, when a conductive liquid moves through that magnetic field, a pair of electrodes measures the voltage induced by the movement of the liquid. The measurement is independent of conductivity changes in the liquid as long as it remains above the minimum threshold of 5 uS/cm².

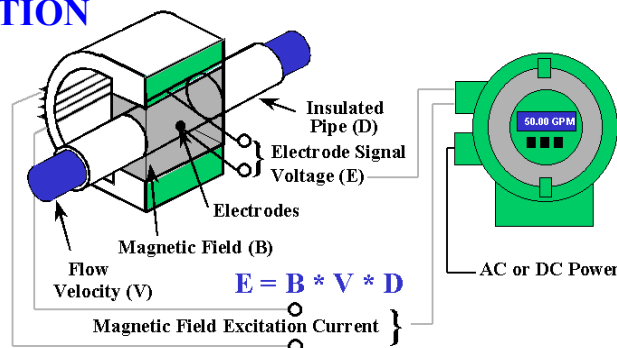

The relationship between the liquid velocity and the induced voltage is expressed in a meter K-factor. The meter K-factor is unique to each and every meter and is documented during a NIST traceable flow test completed prior to shipment. With the K-factor established

a highly accurate volumetric flow is calculated by multiplying the cross sectional area of the flow tube by the measured liquid velocity. This volumetric relationship can then be converted to various engineering units and the flow meter converter can then retransmit this information with a 4-20 mA current signal and / or conditioned pulse. An optional integral LCD Indicator/Totalizer is available to locally display and totalize in whatever engineering units preferred.

METER INSTALLATION

Installation requirements for the Cadillac EMAG are along the line of conventional magnetic flow meters with industry standard for flow profiling or piping straight run.

Employing an industry standard coil design within the flow tube the Cadillac® meter provides an economical alternative for those applications where the CMAG and its unique coil design and focusing plates are not required or necessary for the application.

The electronics for both the CMAG and EMAG are identical and provide high frequency DC square wave signal generation and flow signal sampling. Providing the high reliability and functionality available for a variety of flow applications.

In practice, installation requirements for the EMAG magnetic flow meter follow standard piping straight run requirements, which are listed as follows:

Downstream of the meter:	Upstream of the meter:
◇ Expander (2-5) diameters	◇ Expander - (10) diameters
◇ Tee - (2-5) diameters	◇ Tee - (5) diameters
◇ Elbow - (2-5) diameters	◇ Elbow - (5) diameters
◇ Valves - (2-10) diameters	◇ Valves - (10) diameters

Unlike other technologies such as the Cadillac® Vortex flow meter, magnetic flow meters do not have a low flow cutoff, essentially allowing the meter to read to zero. With such a wide flow range capability for the technology, most applications can be addressed with meters at full line size.

FLOW METER SIZING

The Cadillac® EMAG magnetic flow meter has a carbon steel body and is sold with grounding rings as an option. Grounding rings are optional since most heating/cooling water piping systems have relatively high conductivity and consist of metallic piping, which provides adequate grounding for stray currents traveling through the process water. As a consequence, the induced voltage is remarkably free of noise allowing the meter to reliably measure extremely low fluid velocities. The table below lists minimum as well as maximum flow ranges for each meter size in GPM for liquids.

Magmeter	Liquid Flow Range Table	
Nominal Meter Body (inches) Size	Minimum Volumetric (gal/min) Range	Maximum Volumetric (gal/min) Range
0.5"	0.00 - 0.25	0.00 - 25.00
1"	0.00 - 0.75	0.00 - 75.00
1.25"	0.00 - 1.25	0.00 - 125.0
1.5"	0.00 - 1.75	0.00 - 175.0
2"	0.00 - 3.00	0.00 - 300.0
2.5"	0.00 - 4.75	0.00 - 475.0
3"	0.00 - 6.50	0.00 - 650.0
4"	0.00 - 10.00	0.00 - 1000
5"	0.00 - 17.50	0.00 - 1750
6"	0.00 - 25.00	0.00 - 2500
8"	0.00 - 45.00	0.00 - 4500
10"	0.00 - 70.00	0.00 - 7000
12"	0.00 - 100.00	0.00 - 10000

Traditional Magmeter Piping Requirements

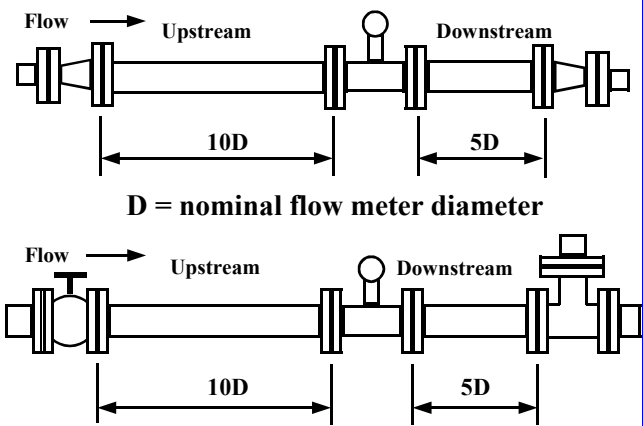

The EMAG flow meter is limited with regard to temperature rating in the smaller line sizes (1/2" to 10") due to the FEP (Teflon) or Polyurethane flow tube liner material. Being much easier to mold the liner materials are very advantageous in construction but limit process service conditions.

Polyurethane: -4°F to 140°F

FEP (Teflon): -4°F to 212°F

In the larger sizes (12" thru 24") PTFE (Teflon) is offered in place of FEP (Teflon), which allows the meter a higher temperature rating.

PTFE (Teflon): -4°F to 212°F

CADILLAC® MAGNETIC FLOW METER

Contact us for Engineering Support

@
Phone: 888-556-3913

Fax: 503-624-6131

Website: www.cadillacmeter.com

E-mail: Cadillacmeter@aol.com

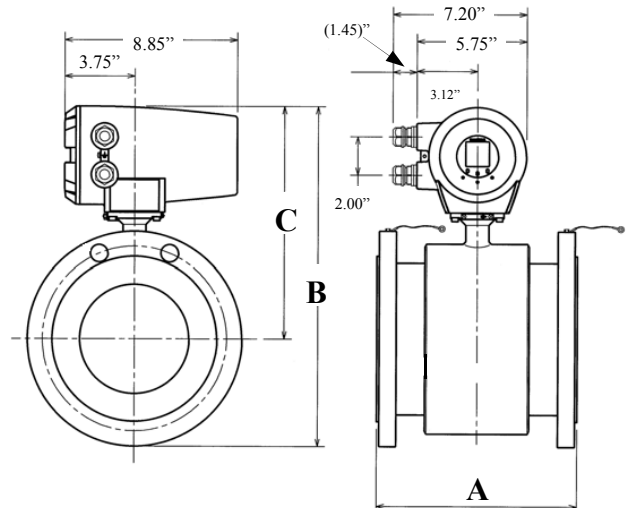

FLANGED EMAG DIMENSIONS

Meter Size	0.5"	1.0"	1.25"	1.5"	2.0"	2.5"	3.0"	4.0"	5.0"	6.0"	8.0"	10.0"	12.0"
"A" (face to face)	7.9"	7.9"	7.9"	7.9"	7.9"	7.9"	7.9"	9.8"	9.8"	11.8"	13.8"	17.7"	19.7"
"B" (top to bottom)	10.4"	11.2"	11.6"	11.9"	12.8"	13.8"	14.3"	15.5"	16.8"	17.8"	20.1"	22.1"	24.6"
"C" (centerline to top)	8.7"	9.1"	9.3"	9.4"	9.8"	10.3"	10.5"	11.0"	11.8"	12.3"	13.3"	14.1"	15.1"
Weight ANSI Class 150lb	16.0	18 lbs	20 lbs	23 lbs	29 lbs	34 lbs	40 lbs	56 lbs	71 lbs	84 lbs	122 lbs	181 lbs	280 lbs

CADILLAC® MAGNETIC FLOW METER GENERAL SPECIFICATIONS

- Meter will consist of a full-bore body with encapsulated and rigidly retained set of coils.
- Meter available with remote or integral electronics with indication and totalization.
- Meter operates at $\pm 0.5\%$ accuracy with proper flow profiling or piping straight run.
- Meter available with pulse and analog (4-20 mA) outputs.
- Meter will provide instantaneous and totalized flow available at local indicator or remotely through outputs.
- Meter measures flow using Faraday's law (Induce voltage is directly proportional to the velocity of the conductive liquid)
- Meter K-factor is stable and not influenced by external piping or mounting orientation.
- Meter will measure fluids with conductivity greater than or equal to 5.0 uS/cm^2 .

CADILLAC® MAGMETER MODEL NUMBER STRUCTURE

EMAG	Cadillac Magnetic Flow Meter
A	Size 0.5"
B	Size 1"
C	Size 1.25"
D	Size 1.5"
E	Size 2"
F	Size 2.5"
G	Size 3"
H	Size 4"
I	Size 5"
J	Size 6"
K	Size 8"
L	Size 10"
M	Size 12" (Consult factory for larger sizes)
II	Integral Converter with Indicator/Totalizer
RC	Remote Converter
F-150	Flanged Body - ANSI Class 150
S	Electrode Material - 316L SS
H	Electrode Material - Hastelloy C
U	Liner Material - Polyurethane 1/2" thru 16"
F	Liner Material - FEP (Teflon) 1/2" thru 10"
P	Liner Material - PTFE (Teflon) 12" thru 24"
W	Ground Ring Material - Without
S	Ground Ring Material - 316 SS
H	Ground Ring Material - Hastelloy C
X	Ground Ring Material - Other
FM	FM Approvals

CC	CMAG Remote Converter
R	Remote Mounting
I	Indicator/Totalizer
U	Universal Mounting Bracket
XXFT	Interconnecting Cable (length in feet)
FM	FM Approvals

APPLICATION NOTE:

The Cadillac® magnetic flow meter is an excellent choice for gravity flow applications. However for proper flow meter operation the piping and flow tube must be full at all times. This requires the meter to be mounted in such a way to provide a "wet leg" as illustrated below.

Gravity flow
with "wet leg" piping

