

Cadillac[®] Magnetic Flow Meter

Central Station Steam Co.[®]

GENERAL INFORMATION

CMAG Series

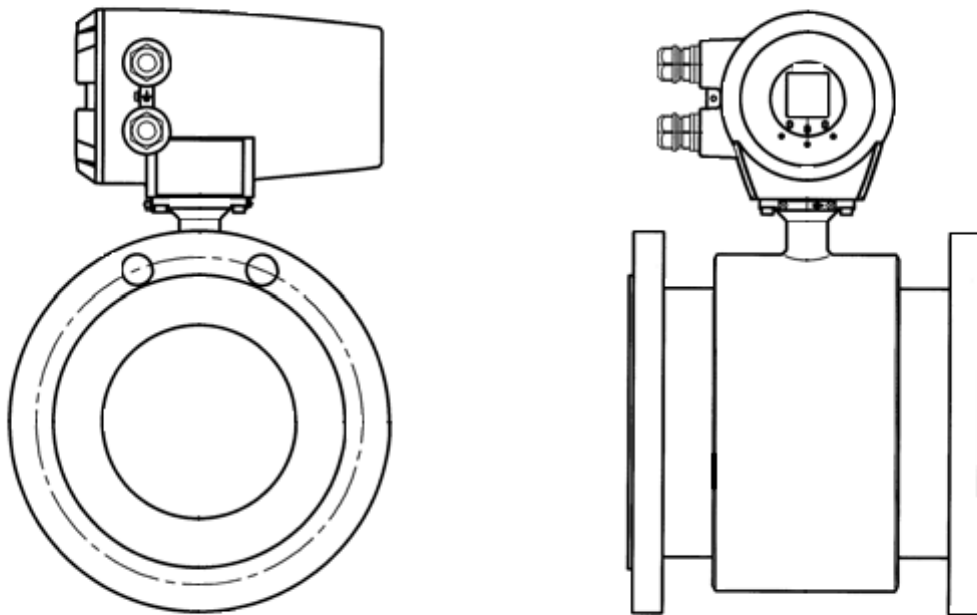

Central Station Steam Co.[®]

CADILLAC[®] METERS

15615 SW 74th Ave., Ste #150

Tigard, OR 97224

www.cadillacmeter.com

Phone: 888-556-3913

Fax: 503-624-6131

THE LIQUID METER OF CHOICE

The Cadillac® magnetic flow meter is a rate and totalizing device, which is capable of measuring liquids of all types and consistency while providing an obstruction free flow path. Due to its robust design, it is particularly suitable for pumped hot condensate as well as hot and chilled water. In any heating/cooling system the Cadillac® magnetic flow meter is the number one technology choice due to Cadillac®'s accuracy, linearity, reliability and rangeability.

Like many other flow meters, the Cadillac® magnetic flow meter is a velocity measuring device which computes flow by multiplying the effective cross sectional area of the flow meter with the detected fluid velocity. The meter has no moving parts and consists of a meter body with encapsulated coils, electrodes and an amplifier assembly. It detects velocity by measuring an induced voltage that is developed by moving the conductive fluid through a magnetic field. For a more detailed explanation, please review the "Principle of Operation" below.

THE NEW INDUSTRY STANDARD

Historically, liquid flows have been measured by mechanical flow meters. However, as with any mechanical system, the meters are subject to wear and tear, and require regular maintenance and calibration. Even though magnetic flow meters have been on the market for years, their high cost of manufacture have limited their use. Current manufacturing technology has made the Cadillac® magnetic flow meter a cost effective solution, especially in applications requiring analog (rate) or pulse (totalized) outputs.

APPLICATIONS

- Data Source for energy management system, DCS, district-wide systems.
- Energy-Customer Billing from accurately totalized flow measurements.
- Basis for internal cost distribution using campus-wide systems.
- Process monitoring from central control rooms.
- Cooling/heating load flows for Hydronic systems.
- Process flows of all liquid types (acids, caustics, abrasives, high suspended solids)

FEATURES

- **ACCURACY: +/-0.25% of the reading for liquids.**
High accuracy allows significant improvement in both measurement and customer billing.
- **RANGEABILITY: Typically 100 to 1 turndown or better.**
With seasonal heating/cooling load variation, the need for a large turndown is essential. Cadillac® magnetic flow meters will accurately measure all load requirements with proper sizing.
- **LONGEVITY: Mean time between failure (MTBF) of 75 years.**
With no moving parts and through simple robust design the meter has unmeasured life expectancy.
- **MODERN ELECTRONICS: meeting the challenges of the next millennium**
Meters are equipped with electronics capable of registering locally, remotely or interfacing with an energy management system. Built to withstand the toughest conditions.

PRINCIPLE OF OPERATION

Faraday's law states that, when you move a conductor perpendicular through a magnetic field, a voltage will be induced proportional to the velocity of the conductor. A magnetic field is created by a set of coils which are encapsulated and rigidly retained in the meter flow tube and, when a conductive liquid moves through that magnetic field, a pair of electrodes measures the voltage induced by the movement of the liquid. The measurement is independent of conductivity changes in the liquid as long as it remains above the minimum threshold of 5 uS/cm².

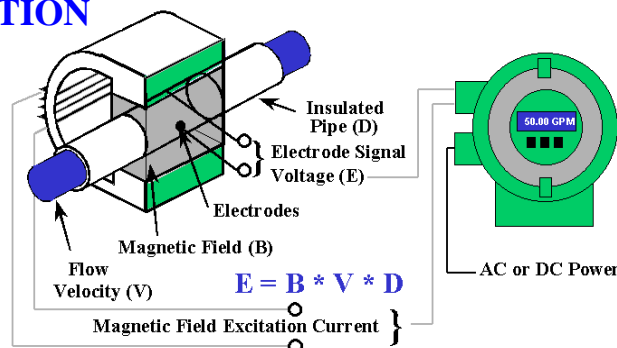

The relationship between the liquid velocity and the induced voltage is expressed in a meter K-factor. The meter K-factor is unique to each and every meter and is documented during a NIST traceable flow test completed prior to shipment. With the K-factor established

a highly accurate volumetric flow is calculated by multiplying the cross sectional area of the flow tube by the measured liquid velocity. This volumetric relationship can then be converted to various engineering units and the flow meter converter can then retransmit this information with a 4-20 mA current signal and / or conditioned pulse. An optional integral LCD Indicator/Totalizer is available to locally display and totalize in whatever engineering units preferred.

METER INSTALLATION

Cadillac Magmeter Piping Requirements

Installation requirements have been redefined with the Cadillac magnetic flow meter.

Employing coil and plate shaping techniques the Cadillac® meter provides a uniform magnetic flux distribution within the flow tube. This allows the meter to measure and sample uniformly the entire flow tube area.

In addition, the electronics provide high frequency DC square wave signal generation and flow signal sampling. When combined these two techniques eliminate all straight run flow profiling requirements.

In practice, this means the Cadillac magnetic flow meters may be installed next to elbows, tees, valves, etc. without any effect in meter accuracy or stability. (See Illustrations)

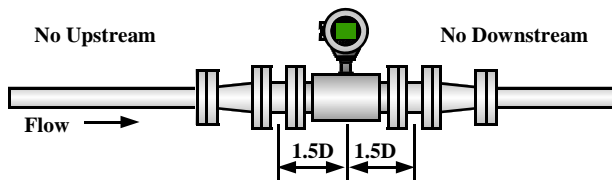

D = nominal flow meter diameter

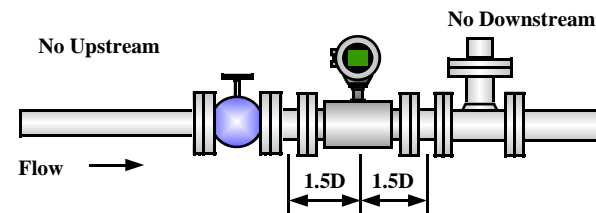

Traditional Magmeter Piping Requirements

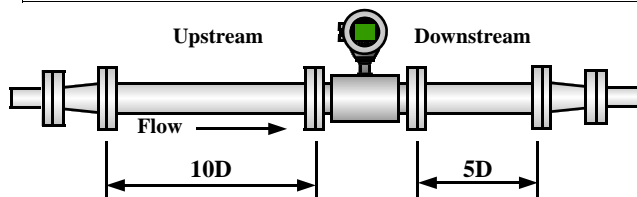

D = nominal flow meter diameter

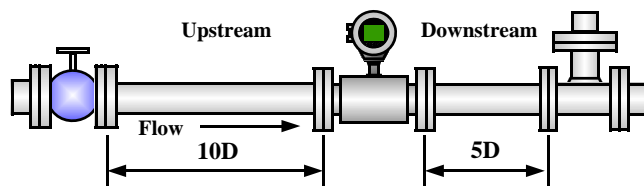

In comparison, the straight pipe run requirements for all other magnetic flow meters are as follows:

- Downstream of the meter:**
 - ◇ Expander (2-5) diameters
 - ◇ Tee - (2-5) diameters
 - ◇ Elbow - (2-5) diameters
 - ◇ Valves - (2-10) diameters
- Upstream of the meter:**
 - ◇ Expander - (10) diameters
 - ◇ Tee - (5) diameters
 - ◇ Elbow - (5) diameters
 - ◇ Valves - (10) diameters

Unlike other technologies such as the Cadillac® Vortex flow meter, magnetic flow meters do not have a low flow cutoff, essentially allowing the meter to read to zero. With such a wide flow range capability for the technology, most applications can be addressed with meters at full line size.

The Cadillac® magnetic flow meter has a 304 stainless steel body and is always sold with grounding rings installed. The primary reason for providing grounding rings is to contain the magnetic field within the meter body and to assure the liquid potential is grounded properly. As a consequence, the induced voltage is remarkably free of noise allowing the meter to reliably measure extremely low fluid velocities. The table below lists minimum as well as maximum flow ranges for each meter size, in GPM for liquids and lbs/hr for condensate.

Magmeter Body (inches) Size	Liquid Flow Range Table		Condensate Flow Range Table	
	Minimum Volumetric (gal/min) Range	Maximum Volumetric (gal/min) Range	Minimum Condensate (lbs/hr) Range	Maximum Condensate (lbs/hr) Range
0.1"	0.00 - 0.024	0.00 - 0.800	0.00 - 12.00	0.00 - 400.0
0.17"	0.00 - 0.061	0.00 - 2.020	0.00 - 30.50	0.00 - 1010
0.25"	0.00 - 0.138	0.00 - 4.585	0.00 - 69.00	0.00 - 2300
0.5"	0.00 - 0.281	0.00 - 28.00	0.00 - 140.0	0.00 - 14000
1"	0.00 - 0.782	0.00 - 78.00	0.00 - 391.0	0.00 - 39000
1.5"	0.00 - 2.000	0.00 - 200.0	0.00 - 1000	0.00 - 100000
2"	0.00 - 3.112	0.00 - 310.0	0.00 - 1556	0.00 - 155000
3"	0.00 - 8.000	0.00 - 800.0	0.00 - 4000	0.00 - 400000
4"	0.00 - 12.50	0.00 - 1250	0.00 - 6250	0.00 - 625000
6"	0.00 - 28.00	0.00 - 2800	0.00 - 14000	0.00 - 1400000
8"	0.00 - 50.00	0.00 - 5000	0.00 - 25000	0.00 - 2500000
10"	0.00 - 78.00	0.00 - 7800	0.00 - 39000	0.00 - 3900000
12"	0.00 - 112.0	0.00 - 11200	0.00 - 56000	0.00 - 5600000

CADILLAC® MAGNETIC FLOW METER

Contact us for Engineering Support

@

Phone: 888-556-3913

Fax: 503-624-6131

Website: www.cadillacmeter.com

E-mail: Cadillacmeter@aol.com

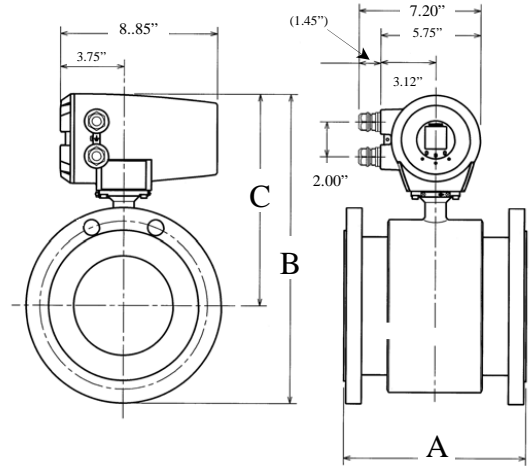

FLANGED CMAG DIMENSIONS

Meter Size	0.5"	1.0"	1.5"	2.0"	3.0"	4.0"	6.0"	8.0"	10.0"	12.0"	14.0"	16.0"
"A" (face to face)	5.50"	6.24"	6.75"	7.13"	9.00"	9.50"	10.25"	11.75"	13.75"	15.75"	17.75"	19.75"
"B" (top to bottom)	10.25"	10.75"	11.5"	12.25"	13.50"	15.00"	17.25"	19.50"	21.63"	24.25"	25.88"	28.00"
"C" (centerline to top)	8.50"	8.60"	8.90"	9.25"	9.80"	10.50"	11.70"	12.75"	13.65"	14.70"	15.35"	16.25"
Weight ANSI Class 150lb	14 lbs	18 lbs	23 lbs	29 lbs	45 lbs	58 lbs	86 lbs	128 lbs	265 lbs	315 lbs	375 lbs	475 lbs

CADILLAC® MAGNETIC FLOW METER GENERAL SPECIFICATIONS

- Meter will consist of a full-bore body with encapsulated and rigidly retained set of coils.
- Meter available with remote or integral electronics with indication and totalization.
- Meter operates at $\pm 0.25\%$ accuracy without flow profiling or piping straight run exceeding 1.5 diameters.
- Meter available with pulse and analog (4-20 mA) outputs.
- Meter will provide instantaneous and totalized flow available at local indicator or remotely through outputs.
- Meter measures flow using Faraday's law (Induce voltage is directly proportional to the velocity of the conductive liquid)
- Meter K-factor is stable and not influenced by external piping or mounting orientation.
- Meter will have uniform magnetic field flux distribution eliminating piping straight run and flow profiling.
- Meter will measure fluids with conductivity greater than or equal to 5.0 $\mu\text{S}/\text{cm}^2$.

CADILLAC® MAGMETER MODEL NUMBER STRUCTURE

CMAG	Cadillac Magnetic Flow Meter
A	Size 0.5"
B	Size 1"
C	Size 1.5"
D	Size 2"
E	Size 3"
F	Size 4"
G	Size 6"
H	Size 8"
I	Size 10"
J	Size 12"
K	Size 14" (Consult factory for larger sizes)
II	Integral Converter with Indicator/Totalizer
RC	Remote Converter
W	Wafer Body (Ceramic Liner) - thru 4" only
F	Flanged Body
150	ANSI Class 150
300	ANSI Class 300
S	Electrode Material - 316L Stainless Steel
X	Electrode Material - Other
C	Liner Material - PFA (Teflon)
D	Liner Material - EPDM (Rubber)
A	Liner Material - Other
S	Ground Ring Material - 316 Stainless Steel
X	Ground Ring Material - Other
FM	FM Approvals

CC	CMAG Remote Converter
R	Remote Mounting
I	Indicator/Totalizer
U	Universal Mounting Bracket
XXFT	Interconnecting Cable (length in feet)
FM	FM Approvals

APPLICATION NOTE:

The Cadillac® magnetic flow meter is an excellent choice for gravity flow applications. However for proper flow meter operation the piping and flow tube must be full at all times. This requires the meter to be mounted in such a way to provide a "wet leg" as illustrated below.

