



DE Steam Traps

Models M10 & GM10

FOR PROCESS AND HEATING SYSTEMS

Designed to handle varying loads of process applications and provide fast start-up and modulating discharge with no live steam loss on services up to 120 psi (8,3 bar) differential pressure.

- **Maximum operating differential pressure:** 120 psig / 8,3 bar
- **Single blade element** – offers long-term, trouble-free service because it's not prone to dirt build-up as encountered with many other bimetal designs
- **Stainless Steel internals** – leads to longer service life since materials are highly resistant to fatigue and corrosion
- **Modulating discharge** – automatically adjusts to operating pressure and load, overcoming problems associated with cyclic discharge
- **Integral strainer and check valve** – strainer protects trap from dirt while check valve prevents backflow during shutdown
- **Continuous air and CO2 venting** – maximizes heat transfer while minimizing corrosion
- **Easy maintenance** – traps are in-line repairable when isolated from live steam system and can be up and running again in minutes



ORDERING SCHEMATIC

MODEL							
M	0	0	1	0	1	1	1

MODEL							
G	M	0	1	0	4	1	0

6	SIZE
1	3/8" (M10)
2	1/2" (All)
3	3/4" (All)
4	1" (GM10)
6	1-1/2" (GM10)
7	2" (GM10)

7	CONNECTIONS
1	NPT
2	FSW
3	150# Flange
4	300# Flange
8	BSPT
9	BSPP

8	SPECIALITIES
0	None
1	DTC
3	Integral Blowdown



FOR PROCESS AND HEATING SYSTEMS

SPECIFICATIONS

Maximum Differential Pressure: 120 PSIG (8,3 bar)

Maximum Operating Pressure: 750 PSIG (52 bar)

Maximum Body Temperature: 650°F (343°C)

MATERIALS

Body & Cover: Forged Carbon Steel A105

Valve Seat 303 SST & Cone: 17-4 SST

Bi-Metal: Stainless Steel NiCr

Strainer: Stainless Steel 304

Bolts: Steel Gr8

Gasket: Flexible Graphite

Options: Double Threaded Strainer Cap (DTC) for blowdown valve attachment; selection of integral blowdown valves

Mounting: From horizontal to vertical (see Installation & Maintenance Instructions). Self-Draining and freeze-resistant when mounted in vertical position.

Line Sizes:

Model M10: 1/2", 3/4", 1", 1-1/2", 2"

Model GM10: 3/8", 1/2", 3/4"

End Connections: Threaded NPT, BSPT, BSPP, SW, Raised Face Flanges (ANSI 150, 300, DIN)

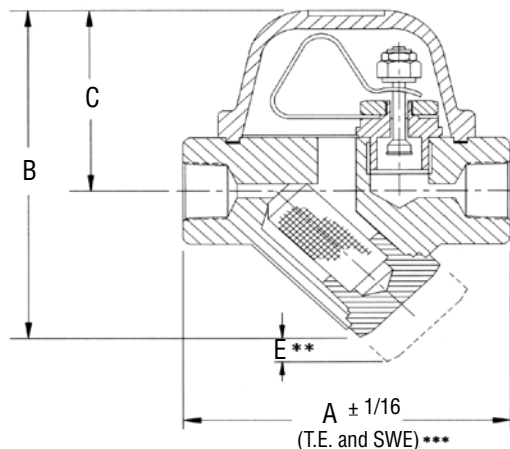

Model M10						
1/2"-3/4"	A	B	C	D	E	Wt
inches	4.00	5.00	3.25	3.125	2.25	5.5 lbs
mm	102	127	83	79	57	2,5 kgs
1"	A	B	C	D	E	Wt
inches	5.00	6.75	3.625	4.00	2.25	9.9 lbs
mm	127	171	92	102	83	4,5 kgs
1-1/2", 2"	A	B	C	D	E	Wt
inches	7.125	9.5	5.875	6.00	4.375	33 lbs
mm	181	241	149	152	111	15 kg
Model GM10						
1/2"-3/4"	A	B	C	D	E	Wt
inches	4.00	5.00	3.25	3.125	2.25	5.5 lbs
mm	102	127	83	79	57	2,5 kgs

Notes: dimension D is overall width; ** dimension E is withdrawal distance for strainer, *** dimensions shown are for threaded or socket weld ends, contact factory for other dimensions

CAPACITY CHARTS: CONDENSATE CAPACITY AT DIFFERENTIAL PRESSURE

Model M10													
Size	Differential Pressure, psi (bar)	10 (0,7)	20 (1,3)	30 (4,1)	40 (2,8)	50 (3,5)	60 (4,1)	70 (4,8)	80 (5,5)	90 (6,2)	100 (6,9)	110 (7,6)	120 (8,3)
3/8"	Cold start-up, lbs/hr	1000	1700	2100	2700	3000	3200	3500	3800	4000	4100	4200	4300
	Hot (Dripleg), lbs/hr	300	350	400	400	400	400	400	400	400	400	400	400
1/2"	Cold start-up, Kg/hr	453	771	952	1224	1361	1451	1587	1723	1814	1859	1905	1950
	Hot (Dripleg), Kg/hr	136	158	181	181	181	181	181	181	181	181	181	181

Model GM10		Consider Model 3A		Consider Model 6A			
Size	Differential Pressure, psi (bar)	20 (1,4)	40 (2,8)	60 (4,1)	80 (5,5)	100 (6,9)	120 (8,3)
1/2"	Cold start-up, lbs/hr	2800	3800	4600	5400	6000	6600
	Hot (Dripleg), lbs/hr	460	550	630	700	750	780
3/4"	Cold start-up, Kg/hr	1270	1723	2086	2449	2721	2993
	Hot (Dripleg), Kg/hr	208	249	285	317	340	353
1"	Cold start-up, lbs/hr	5600	7600	9300	10600	11700	125000
	Hot (Dripleg), lbs/hr	810	1070	1280	1470	1630	1750
	Cold start-up, Kg/hr	2540	3447	4218	4808	5307	5670
	Hot (Dripleg), Kg/hr	367	485	580	666	739	793
1-1/2" & 2"	Cold start-up, lbs/hr	13000	18000	22500	26000	29000	32000
	Hot (Dripleg), lbs/hr	1350	1750	2100	2400	2600	2800
	Cold start-up, Kg/hr	5896	8164	10206	11793	13154	14515
	Hot (Dripleg), Kg/hr	612	793	952	1088	1179	1270

Note: Flow rates are based on discharge to atmospheric pressure, valid for back pressure up to 20% of inlet pressure. Higher back pressure requires reset of control element to obtain these capacities. Consult factory for details.